

[CONTRIBUTION FROM THE LABORATORIES OF THE ROCKEFELLER INSTITUTE FOR MEDICAL RESEARCH]

The Thermodynamic Ionization Constants of Carbonic Acid

BY DUNCAN A. MACINNES AND DONALD BELCHER

Due to their importance in the fields of biology, geology and inorganic chemistry the ionization relations of carbonic acid have received a large amount of investigation. The results of different researches, however, while agreeing among themselves in the orders of magnitude of the two ionization constants, show considerable diversity in the actual figures. The variation is especially great when the published values obtained by potentiometric and conductometric methods are compared. Since the most recent determinations of these important constants two new methods of research have become available. These are galvanic cells without liquid junctions, as developed by Harned and associates, and glass electrodes which can be used in precision measurements. Using these methods we have redetermined the first and second dissociation constants of carbonic acid, attaining, we think, higher accuracy than has been reached in earlier researches. The following pages describe determinations at 25°. Further measurements at 38° will be carried out.

The First Dissociation Constant of Carbonic Acid

The primary dissociation of carbonic acid follows the reaction



and has the dissociation constant

$$K_1 = \frac{(\text{H}^+)(\text{HCO}_3^-)}{(\text{CO}_2)} = \frac{[\text{H}^+][\text{HCO}_3^-] \gamma_{\text{H}} \gamma_{\text{HCO}_3^-}}{[\text{CO}_2] \gamma_{\text{CO}_2}} \quad (1)$$

in which the parentheses represent activities, and the brackets concentrations, of the constituents enclosed. The terms referring to carbon dioxide are here, and in what follows, considered to refer to that substance in solution both as CO_2 and H_2CO_3 .¹ The γ values are activity coefficients of the constituents represented by the subscripts. The method used in this research to obtain the constant K_1 has been to measure potentials of cells of the type

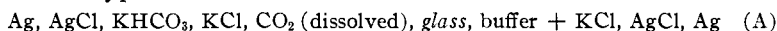

in which the carbon dioxide in the solution is in equilibrium with the gas at a known partial pressure. The reason for the choice of this particular arrangement will be evident after a consideration of the theory of the operation of the cell.

(1) The constant K_1 , which is strictly equal to $(\text{H}^+)(\text{HCO}_3^-)/(\text{CO}_2 + \text{H}_2\text{CO}_3)$, has been shown by Faurholt [*J. chim. phys.*, **21**, 400 (1924)] to be equal to $K_1 = K_t/(1/K_h + 1)$ in which $K_t = (\text{H}^+)(\text{HCO}_3^-)/(\text{H}_2\text{CO}_3)$, the "true" ionization constant of H_2CO_3 , and $K_h = (\text{H}_2\text{CO}_3)/(\text{CO}_2)$. Since K_h is a constant if the activity of the solvent water does not change, K_1 will also be a constant with this same limitation. Thiel and Strohecker [*Ber.*, **47**, 945 (1914)] and Pusch [*Z. Elektrochem.*, **22**, 208 (1916)] have shown that less than 1% of the dissolved carbon dioxide is in the hydrated form H_2CO_3 .

Except for a constant, the portion of the cell

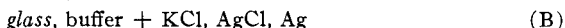

can be considered to be a hydrogen electrode, *i. e.*, one that yields a potential depending upon the hydrogen-ion activity of the solution in which it is immersed. Cell A can thus be treated as if it were of the type

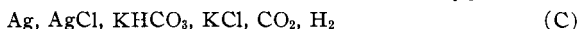

or more simply



with, however, the practical advantage that hydrogen gas is not necessary for the measurements. The potential of cell D is given by the expression

$$E = E_0 + (RT/F) \ln (\text{H}^+)(\text{Cl}^-) = E_0 + (RT/F)(\ln [\text{H}^+][\text{Cl}^-] + \ln \gamma_{\text{H}}\gamma_{\text{Cl}}) \quad (2)$$

Substituting $[\text{H}^+]$ from equation 1 we have

$$E = E_0 + (RT/F) \left[\ln \frac{[\text{CO}_2][\text{Cl}^-] K_1}{[\text{HCO}_3^-]} + \ln \frac{\gamma_{\text{CO}_2}\gamma_{\text{H}}\gamma_{\text{Cl}}}{\gamma_{\text{H}}\gamma_{\text{HCO}_3}} \right] \quad (3)$$

As very good approximations we may assume (a) γ_{CO_2} to be unity and (b) the concentration of carbon dioxide $[\text{CO}_2]$ to follow Henry's law

$$[\text{CO}_2] = SP_{\text{CO}_2} \quad (3a)$$

in which P_{CO_2} is the partial pressure of carbon dioxide and S is a constant. The validity of these assumptions will be discussed later in this article. Equation 3 can thus be put in the form

$$E = E_0 + (RT/F) \ln [\text{Cl}^-]/[\text{HCO}_3^-] + (RT/F) \ln \frac{\gamma_{\text{H}}\gamma_{\text{Cl}}/\gamma_{\text{H}}\gamma_{\text{HCO}_3}}{(RT/F) \ln K_1 SP_{\text{CO}_2}} \quad (4)$$

By choosing $[\text{Cl}^-] = [\text{HCO}_3^-]$ and recalling that the use of the glass electrode in cell A involves another constant, which we will call E_g , equation 4 can be recast in the form

$$pK_1' = pK_1 - \log \gamma_{\text{H}}\gamma_{\text{Cl}}/\gamma_{\text{H}}\gamma_{\text{HCO}_3} = -\frac{E_A - E_0 + E_g}{0.4343(RT/F)} + \log S + \log P_{\text{CO}_2} \quad (5)$$

in which E_A is the potential of Cell A and pK_1' is the negative logarithm of the thermodynamic ionization constant. The value of pK_1' approaches pK_1 as the products $\gamma_{\text{H}}\gamma_{\text{Cl}}$ and $\gamma_{\text{H}}\gamma_{\text{HCO}_3}$ approach unity at infinite dilution.

The experimental portion of this part of the research consisted in the measurement of the potentials of cells of type A at a series of ionic strengths. From these data a value of the ionization constant K_1 was obtained by an extrapolation which will be discussed below. A study was also made of the effect of varying the partial pressure of carbon dioxide on the potential of the cell.

The Apparatus Used in Measuring the First Ionization Constant

The form of cell adopted after considerable experiment is shown in Fig. 1. The vessel A has four openings for closely fitting rubber stoppers through which pass the electrode tubes. The tube marked E carried a silver-silver chloride electrode. It was open at the lower end, and contained the same solution as that in vessel A. The tubes G, G' and G'' are "glass electrodes," that is to say, they are half cells with glass membranes at the points indicated by *m* in the diagram. The construction and use of these

electrodes has been fully described in a series of papers from this Laboratory.² Such electrodes function, with careful use, reversibly to the hydrogen-ion activity, to ± 0.1 mv. within the *PH* range 1 to 8. The electrodes used in this research differed from those previously described in two details. For one thing the solution contained in the mounting

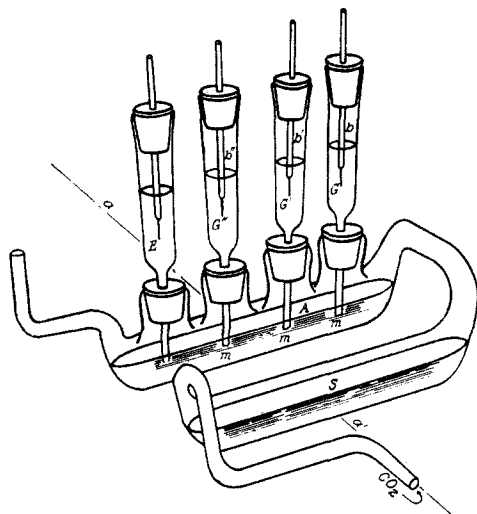
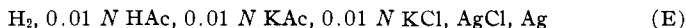

Fig. 1.

and into which the silver-silver chloride electrodes *b*, *b'* and *b''* were inserted consisted of an acetate buffer solution containing potassium chloride (approximately 0.01 *N* acetic acid, 0.01 *N* potassium acetate and 0.01 *N* potassium chloride), instead of the 0.1 *N* hydrochloric acid used in our earlier work. The other change was the enlargement shown in the mounting tube, which was made of Jena thermometer glass 16 III. This made it possible to mount the silver-silver chloride electrodes on rubber stoppers. The sensitive surface of these electrodes was thus prevented from coming into contact with the wall of the tube. This practice resulted in a marked improvement in the steadiness of the potential readings. The stoppers for the electrodes *G*, *G'* and *G''* had capillary openings (not shown) to prevent the building up of pressures which would burst the glass membranes.

Preliminary experiments showed unmistakably that cells of type A would not yield definite potentials if the carbon dioxide were bubbled through the solution in the cell or through the liquid in a vessel used to saturate the gas with water vapor. Strictly, equilibrium cannot be reached under these conditions as the gas is not at a definite pressure. The effect is undoubtedly related to the observations of Winkler,³ Cady, Eelsey and Berger,⁴ and other workers who have found that too high gas solubilities result from violent bubbling or shaking of a gas with its solvent. To avoid such effects the gas was passed slowly in the direction indicated in Fig. 1, over the surface of the solution in the vessel A after passing over solution of the same composition in the saturator S. The whole apparatus was given a gentle rocking motion around the axis *a-a'*. After making this change in the design of the apparatus the potentials reached definite reproducible values.

As already stated, the use of the glass electrode involves an additive constant E_g in the computations. Its value for the present case is that of the potential of the cell



the solution in this cell being that in the glass half cell. This potential was determined with great care for the two solutions used for this purpose in this research. These solutions had only approximately the composition indicated. Definite known compositions are not essential as the electrodes are used for reference only. As pointed out in previous papers the potential of the cell E is equal to that of a cell

(2) MacInnes and Dole, *Ind. Eng. Chem., Anal. Ed.*, **1**, 57 (1929); *J. Gen. Physiol.*, **12**, 805 (1928-1929); *THIS JOURNAL*, **52**, 29 (1930); MacInnes and Belcher, *ibid.*, **53**, 3315 (1931).

(3) Winkler, *Ber.*, **24**, 89 (1891).

(4) Cady, Eelsey and Berger, *THIS JOURNAL*, **44**, 1456 (1922).

H_2 , "solution X," glass, 0.1 N HAc, 0.1 N KAc, 0.1 KCl, AgCl, Ag if the two surfaces of the glass are reversible to the hydrogen-ion activity. This is the case for the glass developed in this Laboratory if "solution X" has a P_H value between about 1 and 8. In obtaining the potential, E_g , of cell E the best available silver-silver chloride electrodes were used, and hydrogen of the highest possible purity, and the usual corrections were made for variation of barometric pressure, and for the vapor pressure of the solution.

In addition a correction for the "asymmetry potential" existing in the glass membrane must be made. This was found by measuring the e. m. f. of the cell

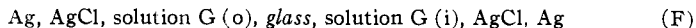

in which "solution G" has the composition of that in cell E and fills the glass half cell. The designations (o) and (i) represent inside and outside that half cell. The silver-silver chloride electrodes inserted into "solution G (o)" were selected with special care, as they are the actual reference electrodes. Any variation in the corresponding electrodes in the glass half cell appears as part of the "asymmetry potentials."

The silver-silver chloride electrodes were made with the kind assistance of Dr. Alfred S. Brown, who has been successful in improving their reproducibility. As the details of his study will be published shortly it will be sufficient to state that the electrodes consist of platinum wires, plated with silver from a bath containing no free cyanide, and finally given a coat of chloride by electrolysis.

Preparation of Solutions and Experimental Procedure

Sodium and potassium chlorides were purified by crystallization from hydrochloric acid solution, followed by centrifuging and drying at 120° . Before use in preparing the solutions they were fused in vacuum, using the Richards bottling apparatus.

Sodium bicarbonate solution was made by passing a slow stream of carbon dioxide through standardized sodium hydroxide solution until a constant weight was reached. The sodium hydroxide solution was standardized to 0.01% against pure benzoic acid from the Bureau of Standards, by differential electrometric titration.⁵

Potassium bicarbonate was prepared in the following manner. A saturated solution of a good commercial grade of the salt, of German origin, was filtered through sintered glass. The solution was then saturated at room temperature with carbon dioxide, and a volume of redistilled alcohol equal to that of the solution added. The mother liquor was then drawn away from the precipitated salt through a sintered glass filter. A further separation of mother liquor was made with a centrifuge. The salt was finally dried over sulfuric acid in a desiccator through which a stream of carbon dioxide gas was passed. For work to be described later in this paper several weighed samples of the bicarbonate were converted to carbonate by fusion in an atmosphere of carbon dioxide. The difference between the observed and expected weight of carbonate was never over 0.3%.

For each stock solution the respective chlorides and bicarbonates were taken in equimolar proportions. For the more dilute solutions used in the cells weighed portions of the stock solution were diluted in standardized volumetric flasks at 25° using conductivity water.

The procedure for a determination was as follows. The clean dry cell, A and S of Fig. 1, was thoroughly rinsed with the solution under investigation. The glass electrodes, G, G' and G'', which had been rinsed with the solution, were then inserted, and a solid rubber stopper was used instead of the stopper carrying the electrode in tube E. The current of carbon dioxide gas was then started and the cell was gently rocked for three hours. The tube E was then filled with the saturated solution in vessel A by

(5) MacInnes and Cowperthwaite, THIS JOURNAL, 53, 555 (1931).

closing the outlet of the gas. The insertion of a rubber stopper carrying a silver-silver chloride electrode completed the cell, which, except for the slight solubility of silver chloride, held a solution of uniform composition throughout. After a further rocking of half an hour potentials were measured at intervals until the readings were found to be constant. A maximum of four hours from the time of assembly of the apparatus was necessary. The readings were made using the potentiometer and electrometer equipment described by MacInnes and Belcher.⁶ The apparatus was kept in a constant temperature room the air temperature of which was regulated within ± 0.1 of 25° . However, a thermometer placed in a small vessel of water or oil indicated temperature variations of $\pm 0.03^\circ$. It is of interest, in connection with the use of the glass electrode, to note that most of the measurements recorded in Tables I and II were made in the summer time when the humidity was high. On account of careful insulation, readings could be made with accuracy with relative humidities up to 75%. At still higher humidities some difficulty was encountered.

The Data for Computing the First Ionization Constant

In Tables I and II, which are largely self-explanatory, are given the experimental data used in obtaining the first ionization constant of carbonic acid. The first of these tables gives the results obtained with cells containing potassium bicarbonate and chloride, and Table II results with the corresponding sodium salts. In both cases the carbon dioxide gas was at approximately atmospheric pressure. The second column of the tables gives E'_A , the measured potential of the cells of type A, and the fourth gives E_A , which is the same potential corrected for the asymmetry potential of the glass electrode. The separate figures for E'_A at each ionic strength are readings of the two or three glass electrodes used. It will be noted that after correcting for the asymmetry potential they yield the same value of E_A within ± 0.1 mv.

TABLE I

DATA FOR THE COMPUTATION OF THE FIRST DISSOCIATION CONSTANT OF CARBONIC ACID
Solutions: Equal Concentrations of KHCO_3 and KCl . CO_2 99.54%. $E_g = -0.6326$ volt.

Ionic strength, μ	E'_A	Asymmetry potential	E_A	Barometric pressure	pK'_1 observed	pK'_1 computed
0.002181	-0.0533	+0.0002	-0.0531	762.5	6.339	6.343
	-.0523	-.0006	-.0529			
.003620	-.0539	+ .0009	-.0530	761.3	6.342	6.343
	-.0530	.0000	-.0530			
	-.0511	-.0019	-.0530			
.004281	-.0539	+ .0006	-.0533	756.0	6.344	6.342
	-.0543	+ .0009	-.0534			
.005058	-.0517	-.0013	-.0530	761.5	6.345	6.342
	-.0527	-.0005	-.0532			
	-.0557	+ .0026	-.0531			
.006814	-.0539	+ .0007	-.0532	754.0	6.342	6.342
	-.0537	+ .0006	-.0531			
	-.0546	+ .0013	-.0533			

(6) MacInnes and Belcher, *THIS JOURNAL*, **53**, 3315 (1931).

TABLE I (Concluded)

Ionic strength, μ	E'_A	Asymmetry potential	E_A	Barometric pressure	pK'_1 observed	pK'_1 computed
0.01109	-0.0528	-0.0002	-0.0530	751.9	6.338	6.342
	- .0523	- .0008	- .0531			
	- .0543	+ .0014	- .0529			
.02130	- .0527	- .0002	- .0529	754.4	6.338	6.340
	- .0524	- .0006	- .0530			
	- .0543	+ .0015	- .0528			
.02139	- .0530	.0000	- .0530	756.2	6.341	6.340
	- .0544	+ .0014	- .0530			
	- .0524	- .0006	- .0530			
.02144	- .0526	- .0004	- .0530	758.1	6.340	6.340
	- .0521	- .0008	- .0529			
	- .0508	- .0021	- .0529			
.02150	- .0539	+ .0009	- .0530	756.2	6.341	6.340
	- .0538	+ .0008	- .0530			
.04020	- .0500	- .0029	- .0529	758.0	6.340	6.338
	- .0502	- .0027	- .0529			
	- .0536	+ .0007	- .0529			
.06194	- .0522	- .0002	- .0524	765.2	6.335	6.336
	- .0511	- .0013	- .0524			
.1006	- .0504	- .0019	- .0523	760.4	6.331	6.331
	- .0500	- .0024	- .0524			
	- .0530	+ .0008	- .0522			
.2486	- .0512	.0000	- .0512	754.3	6.309	6.314
	- .0527	+ .0015	- .0512			
.2486	- .0514	+ .0002	- .0512	757.3	6.309	6.314
	- .0503	- .0008	- .0511			
	- .0509	- .0002	- .0511			

TABLE II

DATA FOR THE COMPUTATION OF THE FIRST DISSOCIATION CONSTANT OF CARBONIC ACID

Solutions: Equal Concentrations of NaHCO_3 and NaCl . CO_2 99.54%. $E_g = -0.6219$ volt.

Ionic strength, μ	E'_A	Asymmetry potential	E_A	Barometric pressure	pK'_1 observed	pK'_1 computed
0.002942	-0.0684	+0.0051	-0.0633	765.5	6.337	6.343
	- .0685	+ .0051	- .0633			
.004357	- .0631	- .0003	- .0634	766.6	6.341	6.343
	- .0629	- .0004	- .0633			
	- .0629	- .0005	- .0634			
.005947	- .0684	+ .0050	- .0634	772.4	6.345	6.342
	- .0679	+ .0045	- .0634			
	- .0681	+ .0047	- .0634			
.009967	- .0632	- .0002	- .0634	769.7	6.344	6.342
	- .0631	- .0002	- .0633			
.01971	- .0678	+ .0046	- .0632	764.3	6.337	6.341
	- .0680	+ .0049	- .0631			
04048	- .0623	- .0009	- .0632	763.7	6.335	6.338
	- .0621	+ .0010	- .0631			

The Computations

Except for a small correction to the results for the more dilute solutions, values of pK'_1 were computed using equation 5. There are two constants that appear in this equation that have been taken from the results of other workers. These are the standard potential of the silver-silver chloride electrode, E_0 , and Henry's law constant, S , of carbon dioxide. A large number of studies have been made for determining the value of E_0 . Hitchcock⁷ has summarized the data up to 1928, and has suggested a convenient method for obtaining this constant from the data. More recent studies are those of Roberts,⁸ Carmody⁹ and Harned and Ehlers.¹⁰ Hitchcock's method applies in the concentration range in which the activity coefficient γ can be expressed with sufficient accuracy by the approximate Debye-Hückel relation

$$-\log \gamma = \alpha \sqrt{C} - BC \quad (6)$$

In this expression C is the concentration of a uni-univalent electrolyte and α ($= 0.5048$ at 25°) and B are constants. The method consists in plotting values of $E - 2RT/F(\log C + \alpha\sqrt{C})$ against the concentration C , E being the potential of the cell Ag, AgCl, HCl (C), H_2 , the slope of the resulting straight line being $-(2RT/F)B$ and the ordinate at zero concentration E_0 . With the aid of Dr. Alfred S. Brown we have applied this method to the data of the three recent researches mentioned above, using, however, the method of least squares instead of a plot. The results of these computations are to 0.1 mv.: from Roberts' data $E_0 = -0.2223$, from Carmody's data $E_0 = -0.2222$, and from Harned and Ehlers' $E_0 = -0.2224$. We will adopt provisionally the mean value, -0.2223 , which agrees with Hitchcock's value obtained from the earlier data. A redetermination of this constant is in progress in this Laboratory.

For Henry's law constant, S , at 25° we have accepted 0.03353 mole/liter atm. which is the mean of the closely agreeing values 0.03357 and 0.03353 from the work of Findlay and associates,¹¹ and the value 0.03350 from a paper by Kunerth¹² interpolated from his results at 24 and 26° .

The partial pressure of carbon dioxide (P_{CO_2} in equation 8) has been taken as equal to the barometric pressure corrected for the vapor pressure of water, and for the composition of the gas. The assumptions involved are discussed in the next section of this paper. The gas used in the experiments outlined in Tables I and II came from a tank which delivered 99.54 mole per cent. carbon dioxide. The barometric pressures were read on a

(7) Hitchcock, *THIS JOURNAL*, **50**, 2076 (1928).

(8) Roberts, *ibid.*, **52**, 3877 (1930).

(9) Carmody, *ibid.*, **54**, 188 (1932).

(10) Harned and Ehlers, *ibid.*, **54**, 1350 (1932).

(11) Findlay and Creighton, *J. Chem. Soc.*, **97**, 536 (1910); Findlay and Shen, *ibid.*, **101**, 1459 (1912); Findlay and Williams, *ibid.*, **103**, 636 (1913); Findlay and Howell, *ibid.*, **107**, 282 (1915).

(12) Kunerth, *Phys. Rev.*, **19**, 512 (1922).

barometer which has been frequently compared with U. S. Weather Bureau standards, and all the usual corrections have been made.

Values of pK'_1 computed from our data are given in the next to the last column of Tables I and II. These values have been computed from equation 5 and their meaning is evident from that equation. At the lower ionic strengths a small correction is, however, necessary, because the concentration of bicarbonate ion arising from the dissolved carbon dioxide must be considered. The computation is made with the formula

$$\frac{(x)(\text{KHCO}_3 + x)}{(\text{CO}_2 + \text{H}_2\text{CO}_3)} = K_1 \quad (7)$$

Using $[\text{KHCO}_3 + x]$ instead of $[\text{HCO}_3^-]$ gives a small value to the term $RT'/F \ln [\text{Cl}]/[\text{HCO}_3^-]$ in equation 4, and this must be carried on to equation 5. For this computation an approximate value of the ionization constant K_1 is ample. For the most dilute solution the correction from this source is 0.3 mv. A plot of the pK'_1 values for the more dilute solutions from Tables I and II is given in Fig. 2. Within the limit of error, about 0.2 mv., the pK'_1 values are seen to vary linearly with the first power of the ionic strength. A larger plot would show this straight line continuing to an abscissa corresponding to $\mu = 0.25$. This plot is, of course, equivalent to the formula

$$pK'_1 = pK_1 - k\mu \quad (8)$$

in which pK_1 is the limiting value of pK'_1 and k is a constant, with the value of 0.119, which was obtained by the method of least squares. The agreement between the observed values and those computed from equation 8 can be seen in the last two columns of Tables I and II. Equation 8 follows from

$$pK'_1 = pK_1 - \log \gamma_{\text{H}}\gamma_{\text{Cl}}/\gamma_{\text{H}}\gamma_{\text{HCO}_3}$$

used in equation 5 if the activity coefficients follow the Debye-Hückel formula

$$-\log \gamma = 0.5048 \sqrt{\mu}/(1 + A\sqrt{\mu}) \quad (9)$$

(in which A is a constant depending on the ionic radius) and if the first term only of the expansion of the resulting expression is retained.

It will be observed from Fig. 2 that the value of pK'_1 varies but slightly with concentration, and that the extrapolation to zero ionic strength can be made without uncertainty. The limiting value, pK_1 , is, from equation 8, 6.343, corresponding to an ionization constant of $K_1 = 4.54 \times 10^{-7}$ for the dissociation of the first hydrogen ion of carbonic acid.

It is of interest to compare the result of this determination with those of other investigators. The early work in this field has been well summarized by Walker, Bray and Johnston¹³ and by Kendall¹⁴ and will be only incidentally discussed here. Kendall's own determination of K_1 at 25° obtained from the measurement of the conductance of solutions

(13) Walker, Bray and Johnston, THIS JOURNAL, 49, 1235 (1927).

(14) Kendall, *ibid.*, 38, 1480 (1916).

of carbonic acid and of sodium bicarbonate is the only one by that method that can be directly compared with our result. His careful experimental work, and his substantial agreement at other temperatures with the results of earlier workers, particularly those of Walker and Cormack,¹⁵ have led many authors to regard his values ($pK_1 = 6.456$, $K_1 = 3.50 \times 10^{-7}$) as more or less final. It will be observed, however, that his constant differs quite seriously from ours. Since the conductometric and potentiometric methods should yield the same value,¹⁶ it was, of course, important to discover which of these results is in error. With the kind assistance of Dr. Theodore Shedlovsky a measurement was made of the conductance

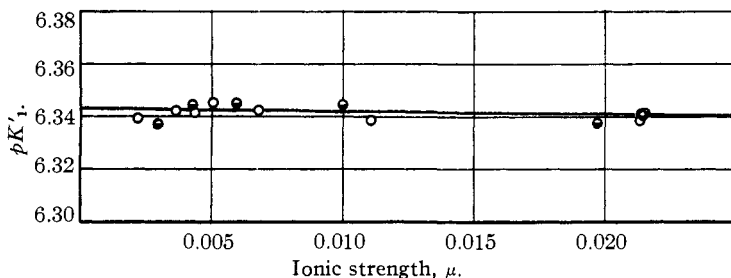

Fig. 2.—Values of pK'_1 as functions of the ionic strength: measurements with potassium salts, \circ ; with sodium salts, \bullet .

of solutions of carbon dioxide saturated at a pressure of about one atmosphere. The close agreement of Henry's law constant obtained by various workers has already been discussed, so that the concentrations of the solutions could be computed with reasonable accuracy. The pipet cell of the Jones and Bollinger type¹⁷ and the bridge¹⁸ used in the measurement have been described elsewhere. In saturating the water, which had a conductance of about 0.3×10^{-6} , an apparatus similar to that shown in Fig. 1 was used to avoid possible supersaturation. The results are shown in Table III.

TABLE III

DETERMINATION OF THE FIRST DISSOCIATION CONSTANT OF CARBON DIOXIDE BY THE CONDUCTOMETRIC METHOD

No.	Barometric pressure	Concentration	Equiv. cond. Δ	$K_1 \times 10^7$	pK_1
1	769.9	0.03276	1.433	4.27	6.370
2	769.9	.03276	1.444	4.36	6.361
3	772.1	.03280	1.454	4.42	6.35 \pm
Average 4.35					6.362

(15) Walker and Cormack, *J. Chem. Soc.*, **77**, 5 (1900).

(16) Almost identical ionization constants for acetic acid have been obtained by Harned and Ehlers [THIS JOURNAL, **54**, 1350 (1932)] by the electrometric method, and by MacInnes and Shedlovsky [*ibid.*, **54**, 1429 (1932)] by the conductometric method, the constants found being, respectively, 1.754 and 1.753×10^{-5} .

(17) Jones and Bollinger, THIS JOURNAL, **53**, 411 (1931).

(18) Shedlovsky, *ibid.*, **52**, 1793 (1930).

The average value of the ionization constant obtained in these experiments agrees reasonably well with our figure (4.54×10^{-7}) but is quite different from that of Kendall (3.50×10^{-7}). In computing the concentrations the pressure was corrected for the aqueous tension and for the slight impurity of the carbon dioxide gas. The computation of K_1 was made using Ostwald's dilution law and 396.6 from the "International Critical Tables"¹⁹ for the limiting conductance of carbonic acid. Because of the low ion concentration no corrections are necessary for activities or changing ion mobilities. These conductometric results may be regarded as preliminary but are quite sufficient to show, within the experimental error, that the conductometric and potentiometric methods will yield the same result for the ionization constant. The errors in the earlier work by the conductometric method probably arose from the difficulty of analyzing dilute solutions of a very volatile substance.

On the other hand, our result agrees quite well with some of the earlier determinations by the potentiometric method. Thus Michaelis and Rona²⁰ found $pK_1 = 6.356$, $K_1 = 4.40 \times 10^{-7}$ at 22°. Also, interpolating between Hasselbalch's²¹ values at 18 and 38° for a value at 25° yields $pK_1 = 6.37$ in rough agreement with our result. Warburg's pK_1 values are higher. It is, however, difficult to obtain definite conclusions from the last two researches mentioned as the data are not very accurate. The result $pK_1 = 6.33$ ($K_1 = 4.68 \times 10^{-7}$) from Hastings and Sendroy's²² careful study at 38° is very close to ours and indicates that the constant has not as large a temperature coefficient as would be indicated from earlier determinations.

The Effect of the Partial Pressure of Carbon Dioxide.—Up to the present we have assumed that the effect of changing partial pressure of carbon dioxide on the potential of a cell of type A is correctly represented by the term: $(RT/F) \cdot \ln P_{\text{CO}_2}$ of equation 4. This has not, however, been proved experimentally. It therefore seemed desirable to study the effect of wide variations in the composition of the gas used in the measurements. The results of this part of the investigation are given in Table IV.

TABLE IV
THE EFFECT OF THE PARTIAL PRESSURE OF CARBON DIOXIDE

Mole per cent. of CO ₂	Barometric pressure	Partial pressure CO ₂ (atm.)	E. m. f. of cell A	
			Observed	Computed
99.59	726.4	0.9674	-0.0528	-(0.0528)
30.50	761.9	.2962	-.0832	-.0832
12.03	763.1	.1170	-.1069	-.1071
0.54	758.0	.0052	-.1872	-.1870

Tanks of gas having the mole percentage of carbon dioxide given in the

(19) "International Critical Tables," Vol. VI, p. 261.

(20) Michaelis and Rona, *Biochem. Z.*, **67**, 182 (1914).

(21) Hasselbalch, *ibid.*, **30**, 317 (1910); **78**, 112 (1916-1917).

(22) Hastings and Sendroy, *J. Biol. Chem.*, **68**, 445 (1925).

first column of the table were prepared by mixing the commercial gas with commercial nitrogen, and allowing the resulting mixtures to stand long enough to attain uniformity of composition. The analyses of these mixtures were made with the kind assistance of Drs. Van Slyke and Sendroy, of this Institute, using the Van Slyke apparatus. The potential measurements recorded in the table were made as described earlier in this paper, except that a gas mixture was passed through the cell shown in Fig. 1 instead of nearly pure carbon dioxide. The observed potential of cell A using the gas mixtures listed in the first column of the table are given in the next to the last column, and are plotted against the logarithm of the partial pressure of carbon dioxide in Fig. 3. It will be seen that the points fall accurately on a straight line which has the theoretical slope 0.0592.

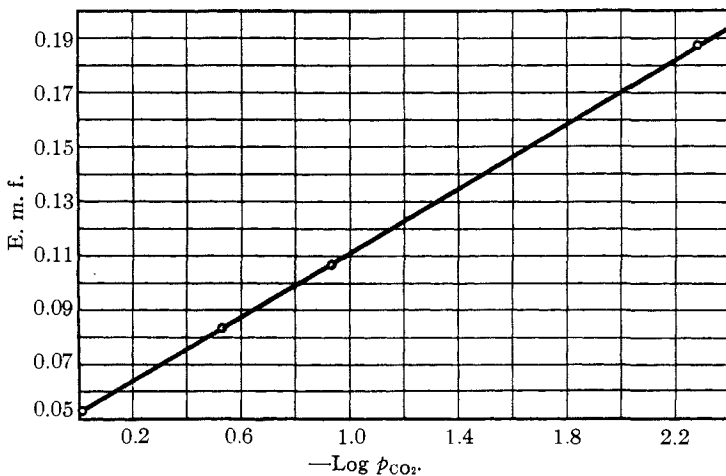

Fig. 3.—The effect of the partial pressure of carbon dioxide on the electromotive force.

The agreement of theory and experiment is also shown in the close agreement of the observed potentials with the computed values given in the last column of Table IV. This work shows that, within the experimental error, the partial pressure, or, more strictly the fugacity, of the carbon dioxide is proportional to its mole fraction as assumed by Lewis and Randall.²³ At higher pressures this would not be true, as has been shown by Pollitzer and Streubel,²⁴ Lurie and Gillespie²⁵ and by Gibson and Sosnick.²⁶

In this connection it may be well to recall that the equation for Henry's law, $\text{CO}_2 = SP_{\text{CO}_2}$, is not thermodynamic. A thermodynamically correct expression is: $(\text{CO}_2) = CF_{\text{CO}_2}$ in which C is a true constant and F_{CO_2} is the fugacity of carbon dioxide. However, the activity coefficient of

(23) Lewis and Randall, "Thermodynamics," p. 227.

(24) Pollitzer and Streubel, *Z. physik. Chem.*, **110**, 768 (1924).

(25) Lurie and Gillespie, *THIS JOURNAL*, **49**, 1146 (1927).

(26) Gibson and Sosnick, *ibid.*, **49**, 2172 (1927).

dissolved carbon dioxide must be very nearly unity, and at one atmosphere the fugacity of pure carbon dioxide gas is 0.997²⁷ so that no correction has been made for these effects in computing K_1 .

Measurements such as have just been described may be used as a method of analysis for the carbon dioxide content of air or other suitable gas mixtures. Wilson, Orcutt and Peterson²⁸ have tested such a method, using, however, a cell arrangement less well adapted to the purpose than the one shown in Fig. 1.

The Second Dissociation Constant of Carbonic Acid.—The second dissociation constant of carbonic acid

$$K_2 = \frac{(\text{H}^+)(\text{CO}_3^{--})}{(\text{HCO}_3^-)} = \frac{[\text{H}^+][\text{CO}_3^{--}]}{[\text{HCO}_3^-]} \frac{\gamma_{\text{H}}\gamma_{\text{CO}_3}}{\gamma_{\text{HCO}_3}} \quad (10)$$

was obtained from measurements of cells without liquid junction of the type



The theory of these cells is as follows. Since one electrode is reversible to the chloride ion and the other to the hydrogen ion the potential of the cell, E , is given by

$$E = E_0 + (RT/F) \ln (\text{H}^+)(\text{Cl}^-) = E_0 + (RT/F) (\ln [\text{H}^+][\text{Cl}^-] + \ln \gamma_{\text{H}}\gamma_{\text{Cl}}) \quad (11)$$

Substituting $[\text{H}^+]$ from equation 10 in equation 11 and setting $pK_2 = -\log K_2$ we obtain the expression

$$pK_2' = pK_2 - \log \frac{\gamma_{\text{H}}\gamma_{\text{HCO}_3}\gamma_{\text{Cl}}}{\gamma_{\text{H}}\gamma_{\text{CO}_3}} - \frac{E - E_0}{0.4343(RT/F)} + \log \frac{[\text{HCO}_3^-][\text{Cl}^-]}{[\text{CO}_3^{--}]} \quad (12)$$

in which pK_2' is defined by the equation itself and approaches pK_2 as the activity coefficients approach unity at low ionic strengths. Using the apparatus to be described in the next section the potentials of cells of type G were measured at a series of ionic strengths. From these measurements the value of pK_2 was obtained by means of an extrapolation which will be described below.

The Apparatus for Measuring the Second Dissociation Constant of Carbonic Acid

The apparatus used in determining the second dissociation constant of carbonic acid is shown in Fig. 4. The cell consisted of the vessel A, into which projected two hydrogen electrodes, e—e, and the vessel B containing two silver-silver chloride electrodes, e'—e', the two vessels being connected by the ungreased stopcock S. Hydrogen gas was led into vessel A through the tube T which penetrated just under the solution in the cell. The gas passed out through a trap P. The whole apparatus was gently rocked about an axis a—a'. The reasons for this particular design, which is the result of considerable preliminary work, are as follows. Although the solutions in vessels A and B have the same composition, one of them is saturated with silver chloride and contains a small amount of oxygen, neither of which can reach a hydrogen electrode without affecting its potential. To prevent mixing of the two portions of the solution the stopcock S

(27) Ref. 23, p. 192.

(28) Wilson, Orcutt and Peterson, *Ind. Eng. Chem., Anal. Ed.*, **4**, 356 (1932).

was kept closed except when the rocking was stopped and measurements were being made. The tube T was inserted after it was found that equilibrium was attained very slowly if the hydrogen gas merely passed over the surface of the solution, even when it was agitated by rocking. By gently breaking the surface with gas bubbles constant potentials were rapidly obtained, apparently without any of the supersaturation effects mentioned earlier in this paper.

There was an additional difficulty that had to be overcome before constant reproducible potentials could be obtained. This arose from the fact that a carbonate-bicarbonate mixture has an appreciable equilibrium pressure of carbon dioxide, and the result of passing a gas through it is to increase the proportion of carbonate. This phenomenon has been described by Walker, Bray and Johnston,²⁹ who measured the potentials of cells similar to those of type G, except that they involved a liquid junction. In our work the composition of the solution in the cell was kept constant by giving the hydrogen gas a preliminary saturation with carbon dioxide at the equilibrium pressure by means of the saturator M—M' which contained solution of the same composition as that in the cell. This saturator was of the form designed by Berkeley and Hartley,³⁰ and used by Washburn and Heuse,³¹ and others. This arrangement makes it possible to pass the gas over a large area of freshly formed surface of solution without building up appreciable pressure differences.

In preparing the solutions used in the cell and saturator, separate stock solutions of the three components were first made up by weight. The requisite portions of these solutions were then measured out into carefully standardized volumetric flasks with weight burets and a good grade of conductivity water added.

The Data for Computing the Second Dissociation Constant of Carbonic Acid.—The measurements on cells of type G used in computing the second dissociation constant of carbonic acid are collected in Tables V and VI. In the first three columns of these tables are given the concentrations of the three components of the solutions, and in the fifth column the corresponding potentials of the cells containing these solutions. These potentials have been corrected in the usual way for the barometric pressure and the vapor pressure of water. In Table V the proportions of chloride, bicarbonate and carbonate are roughly 1:1:1, whereas in Table VI they are approximately 3:3:1.

Values of pK'_2 , *i. e.*, the negative logarithm of the apparent second ionization constant, have been computed from these data by means of equation 12, and are given in the last column of the tables. However, since the proportions of carbonate and bicarbonate have been appreciably altered by the hydrolysis $K_2CO_3 + H_2O = KHCO_3 + KOH$, the concentrations of these substances as given in the appropriate columns of Tables V and VI cannot be used without correction. This correction may be made by means of the equation

$$\frac{(X)(C_{KHCO_3} + X)}{(C_{K_2CO_3} - X)} = \frac{K'_w}{K'_2}$$

in which X is the concentration of hydroxide and also the amount of carbonate transformed by the hydrolysis into bicarbonate. Since, for substi-

(29) Walker, Bray and Johnston, *THIS JOURNAL*, **49**, 1235 (1927).

(30) Berkeley and Hartley, *Proc. Roy. Soc. (London)*, **A77**, 156 (1906).

(31) Washburn and Heuse, *THIS JOURNAL*, **37**, 309 (1915).

tution into equation 12 we desire concentrations and not activities the apparent stoichiometric constants, at each value of the ionic strength, for the dissociation of water, K'_w , and for the second dissociation of carbonic acid, K'_2 , were used in the computation. Values of K'_w have been taken from the work of Harned³² and preliminary values of K'_2 were obtained from the data in Tables V and VI using equation 12 without the small correction under consideration. The resulting values of X are given in the fourth columns of the tables. A second approximation could, of course, have been made, but was not necessary. Now using the corrected concentrations of carbonate and bicarbonate a series of values of pK'_2 were computed. These are given in the final column of the tables.

TABLE V

DATA FOR COMPUTING THE SECOND DISSOCIATION CONSTANT OF CARBONIC ACID AT 25°
Concentration Ratio 1:1:1

KCl	Moles per liter KHCO ₃	K ₂ CO ₃	$x \times 10^4$	$\sqrt{\mu}$	E. m. f.	pK'_2
0.002512	0.002512	0.002201	1.50	0.1064	-0.9729	10.207
.004447	.004451	.004403	1.96	.1473	-.9615	10.192
.005704	.005704	.004999	1.83	.1614	-.9528	10.197
.006276	.006282	.006214	2.11	.1753	-.9529	10.187
.009412	.009420	.009318	2.19	.2152	-.9420	10.171
.01154	.01154	.01011	1.94	.2303	-.9333	10.159
.01358	.01358	.01190	1.96	.2499	-.9292	10.159
.01593	.01594	.01577	2.30	.2806	-.9274	10.143
.03001	.03001	.02630	1.90	.3723	-.9059	10.101
.04718	.04718	.04134	1.94	.4670	-.8930	10.077

TABLE VI

DATA FOR COMPUTING THE SECOND DISSOCIATION CONSTANT OF CARBONIC ACID AT 25°
Concentration Ratio 3:3:1

KCl	Moles per liter KHCO ₃	K ₂ CO ₃	$x \times 10^4$	$\sqrt{\mu}$	E. m. f.	pK'_2
0.003851	0.003315	0.001185	0.65	0.1028	-0.9411	10.224
.007287	.006274	.002242	.78	.1419	-.9249	10.211
.01050	.009043	.003232	.80	.1705	-.9154	10.204
.01436	.01237	.004420	.82	.1996	-.9066	10.187
.02147	.01848	.006605	.83	.2440	-.8949	10.161

To obtain the limiting value of pK'_2 it has been plotted as is shown in Fig. 4 against the square roots of the corresponding ionic strengths, the result being a straight line. Using the method of least squares on the data in Table V a value of pK_2 of 10.251 ($K_2 = 5.61 \times 10^{-11}$) and of the slope of the line of 0.382 were found.

A slightly different value of the constant would have been obtained if the data of Table VI had been included in the computations just described, since these results appear to be subject to a somewhat greater experimental error than those recorded in Table V. The differences are,

(32) Harned, THIS JOURNAL, 47, 930 (1925).

however, very small, as can be seen from a comparison of the two sets of pK'_2 values in Fig. 4. The two sets of results also show that, within the experimental error, the pK'_2 values are independent of the proportion of carbonate and depend only on the ionic strength.

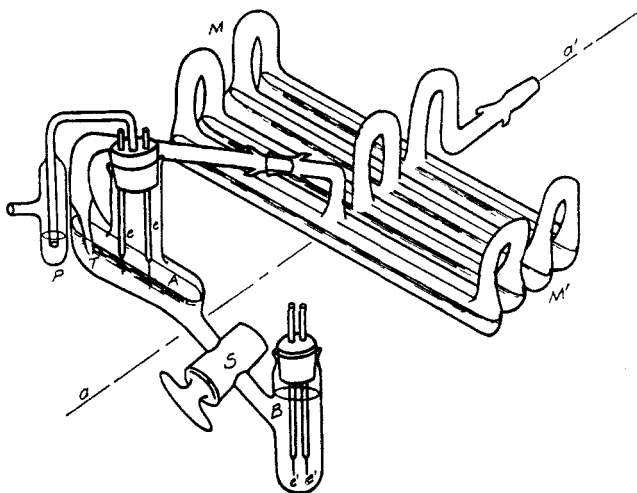
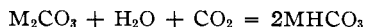

Fig. 4.

Although the plot shown in Fig. 4 is of the form required by equation 12 and the first term of the Debye-Hückel expression for the activity coefficients the slope of the line, 0.382, is very different from the value, 1.01, predicted by the theory. A similar difference between the predicted and observed slope has been observed by Hastings and Sendroy. Very little is known at the present time concerning activities in mixtures containing singly and doubly charged ions. It therefore seems best, for the present, to regard the extrapolation shown in Fig. 4 as empirical.

The figure just given for the second dissociation constant of carbonic acid agrees in order of magnitude, at least, with previous determinations at or near 25°. However, such determinations have consisted, not of independent evaluations of the constant, but, by means of measurements of chemical equilibria, of finding the ratio of K_2 to K_1 , and are thus subject to at least as much error as is the latter constant. For example, McCoy,³³ and Walker, Bray and Johnston¹³ have studied the equilibrium



in which M is one of the alkali metals. According to the mass action law the expression

$$\frac{(MHCO_3)^2}{(M_2CO_3)(CO_2)} = \frac{K_1}{K_2}$$

(33) McCoy, *Am. Chem. J.*, **29**, 437 (1903).

is true for this equilibrium. Lewis and Randall³⁴ have deduced the limiting values of 6300, 9400 and 8700 for K_1/K_2 from the experimental work of McCoy, though they favor the second figure given. From their extensive experimental work Walker, Bray and Johnston obtain 9100 for the ratio. These figures are in very rough agreement with the ratio 8090 from the results given in this paper. Similar computations from data on chemical equilibria, and involving the early K_1 values have been made by Bodländer,³⁵ Seyler and Lloyd,³⁶ and others, and yield K_2 values of the order of magnitude of 10^{-11} .

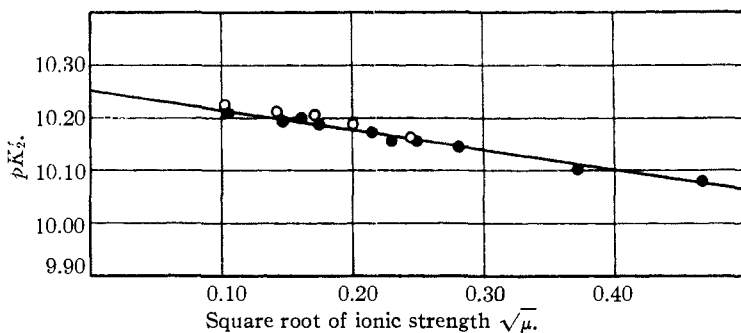
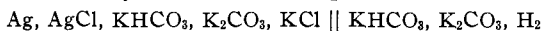

Fig. 5.—Value of pK'_2 as functions of the square root of the ionic strength: Ratio 1:1:1 = ●; Ratio 3:3:1 = ○.

Measurements from which independent values of K_2 may be deduced were made by Walker, Bray and Johnston, although these authors did not make the computations. They determined the potentials of cells of the type



Except for a liquid junction, which would be expected to have a very low potential, these cells are very similar to the cells of type G, measurements of which are described in this paper. The pK'_2 values resulting from these data, while reasonably in accord with our results, are pretty much scattered when plotted in the way represented by Fig. 4. The experimental errors probably arose from the analyses of the solutions, the carbonate being as low in concentration as 0.0009 mole per liter.

We have already mentioned the similarity of our value of K_1 to that obtained at 38° by Hastings and Sendroy, by means of cells with liquid junctions. The two values of K_2 are also very nearly the same, *i. e.*, 5.51×10^{-11} at 25° and 6.03×10^{-11} at 38° , though a difference would be expected on account of the different temperature. It is possibly relevant to mention that Harned and Ehlers¹⁰ find that the thermodynamic ionization constant of acetic acid changes almost inappreciably in the temperature range 25 to 35° .

(34) Lewis and Randall, *THIS JOURNAL*, **37**, 458 (1915); "Thermodynamics," pp. 311 and 578.

(35) Bodländer, *Z. physik. Chem.*, **35**, 23 (1900).

(36) Seyler and Lloyd, *J. Chem. Soc.*, **111**, 994 (1917).

Summary

This paper describes determinations at 25° of the first and second dissociation constants of carbonic acid. The methods used involved galvanic cells without liquid junctions and glass electrodes suitable for precision measurements. The results obtained are 4.54×10^{-7} for the first and 5.61×10^{-11} for the second thermodynamic dissociation constant. The first of these figures is considerably at variance with published, and generally accepted, values of the constant obtained from conductivity measurements, but is in close accord with a redetermination by that method described in this paper. It also agrees with the potentiometric measurements of Michaelis and Rona. The second constant is in accordance, in order of magnitude, with published work based on equilibrium measurements. The new potentiometric method, however, makes much greater accuracy possible.

A study has also been made of the fugacity of carbon dioxide in mixtures with nitrogen at one atmosphere total pressure.

NEW YORK, N. Y.

RECEIVED FEBRUARY 1, 1933
PUBLISHED JULY 6, 1933

[CONTRIBUTION FROM THE CHEMISTRY DEPARTMENT OF THE STATE UNIVERSITY OF IOWA, IOWA CITY, IOWA]

A Determination of the Heat of Reaction of $2\text{Fe}(\text{ClO}_4)_3 + 2\text{Hg} = 2\text{Fe}(\text{ClO}_4)_2 + \text{Hg}_2(\text{ClO}_4)_2$ from Equilibrium Data¹

BY VERNON B. FLEHARTY

The present investigation consists of repeating at 35° a study of the equilibrium condition of the reaction

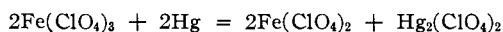

previously made at 25° by Popoff, Fleharty and Hanson.² By combining the results of the two investigations the heat of reaction $2\text{Fe}^{++}\alpha \text{ Aq} + 2\text{Hg}(1) = 2\text{Fe}^{++}\alpha \text{ Aq} + \text{Hg}_2^{++} \alpha \text{ Aq}$ can be computed.

Preparation of Materials.—The preparation of materials was carried out according to Popoff, Fleharty and Hanson.²

Analytical Methods.—The analytical methods were according to Popoff, Fleharty and Hanson² except that the mercurous-ion concentration was calculated from the determined concentration of ferrous ion. This was considered precise enough, since after making thirty-six mercurous ion determinations according to Popoff, Fleharty and Hanson² and comparing them with the corresponding ones calculated from the ferrous ion determination, it was discovered that eighteen were above and eighteen were below the calculated values.

Equilibrium was attained at 35° by a method similar to that used at 25°.² The reaction was allowed to take place in Pyrex glass bottles which could be glass sealed.

(1) The problem was suggested by Dr. Stephen Popoff and the author wishes to thank Dr. Eversole for his help during Dr. Popoff's illness.

(2) Popoff, Fleharty and Hanson, *THIS JOURNAL*, **53**, 1643 (1931).